

SE Sem III Choice Based (R-19 'C' scheme) - Summer 2025

Time: 3 Hrs

Marks: 80

ELEC

4-6-25

Note:

- Question No. 1 is compulsory.
- Answer any three from the remaining five questions.
- Assume suitable data if necessary and justify the same.

Q1 Each question carries five marks

20M

- a In the given network, assuming all initial conditions as zero, find i_1, i_2 at $t=0+$.

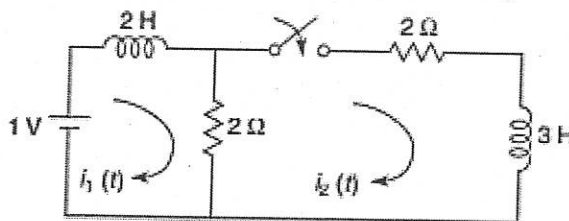

- b Derive the condition for reciprocity and symmetry for ABCD-parameters.
 c Determine the current through the 20 ohm in the following circuit

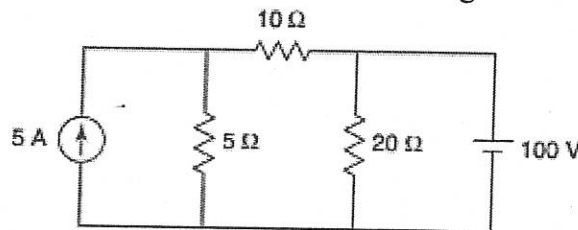

- d Obtain the pole-zero plot of the function $F(s) = \frac{s(s+6)}{(s+1)(s+5)}$

- Q2 a For the network shown, the switch is closed at $t = 0$. Find the currents $i_1(t)$ and $i_2(t)$, when initial current through the inductor is zero and initial voltage on the capacitor is 4V, using Laplace Transform. 10M

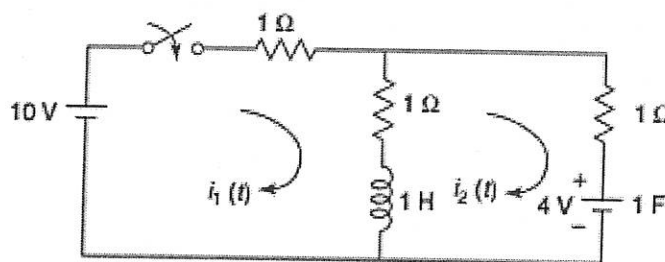

- b For the given graph, write the incidence matrix, tieset matrix and f-cutset matrix. 10M

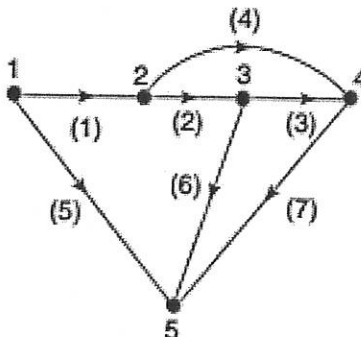

- Q3 a Determine the transmission parameters of the network shown using the concept of interconnection of two two-port networks. 10M

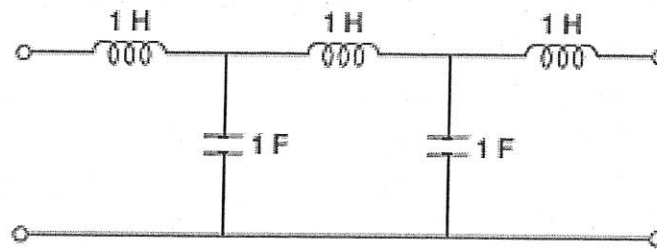

- b Find the voltage V using superposition theorem. 10M

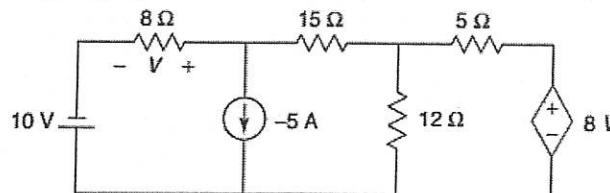

- Q4 a Find the value of the resistance R_L for maximum power transfer and calculate the maximum power. 10M

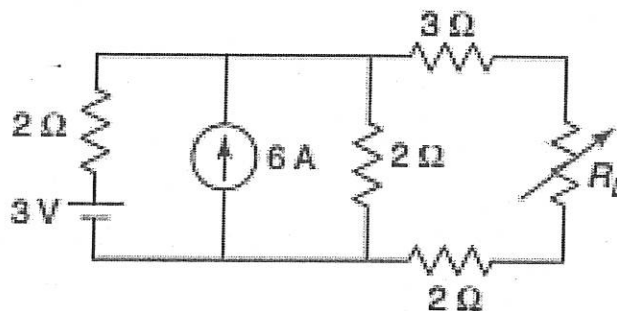

- b For the following network, steady state is reached with the switch closed. The switch is opened at $t = 0$. Obtain expressions for $i_L(t)$ and $v_L(t)$. 10M

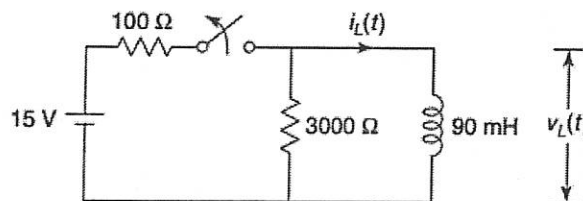

- Q5 a For the given ladder network, determine the voltage transfer function V_2/V_1 . 10M

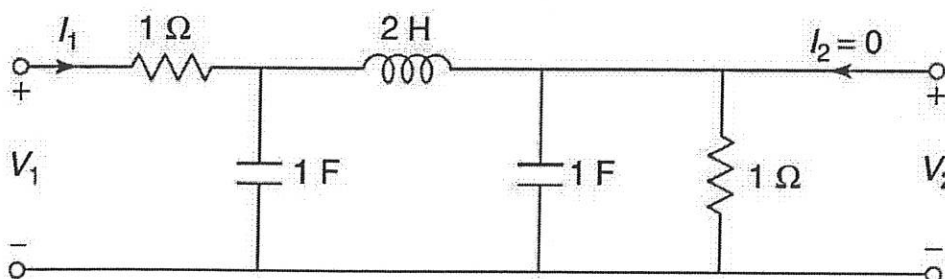

- b For the given network, find the driving-point admittance Y_{11} and transfer admittance Y_{12} 10M

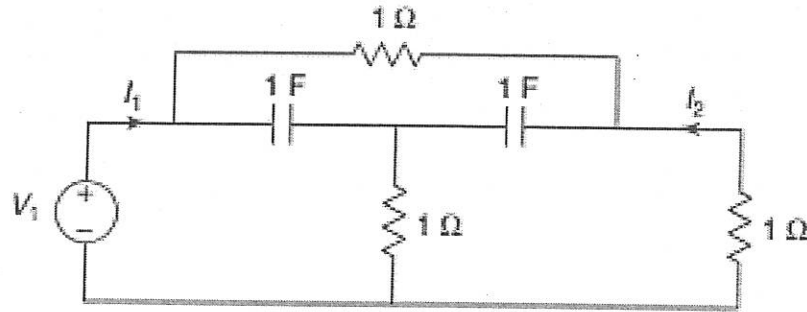

- Q6 a Determine the voltage across the 15Ω resistor using mesh analysis. 10M

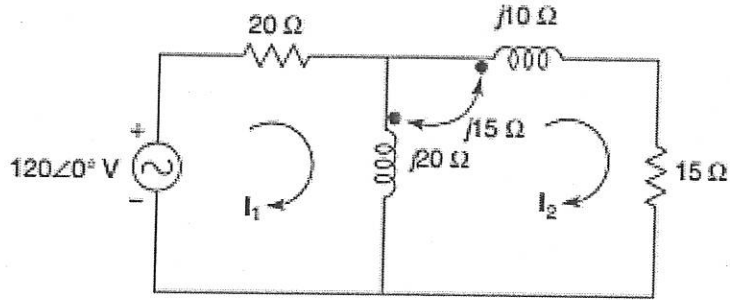

- b For the given network, poles and zeros of driving point function $Z(s)$ are, poles: $(-1 \pm j4)$; zero: -2 . If $Z(j0) = 1$, find the values of R , L and C . 10M

