

Time : 3 Hour

Marks: 80

Note: Question No. 1 Compulsory.

Q.1 Attempt any four questions:- (20)

- a) Define open loop system and explain with one example. (5)
- b) Find the Transfer functions of Electrical networks shown in figure (5)

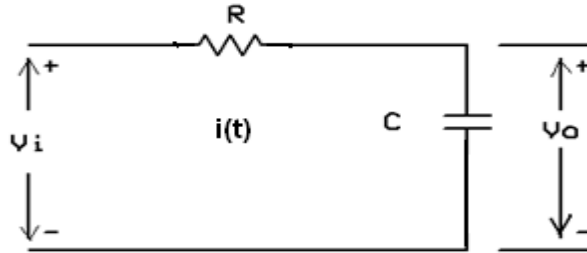

- c) Explain Mason's gain formula (5)
- d) Explain Controllability and Observability with its necessity condition for stability. (5)
- e) Draw the time response for following pole locations. (5)

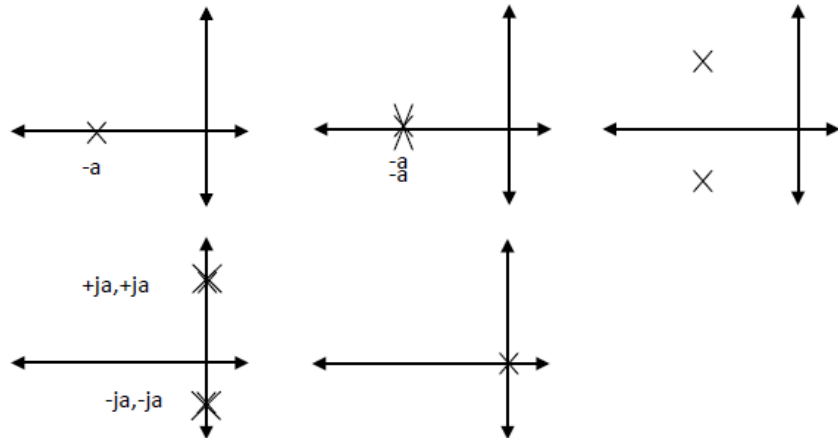

Q.2 a) Obtain C(s)/R(s) using block diagram reduction rules. (10)

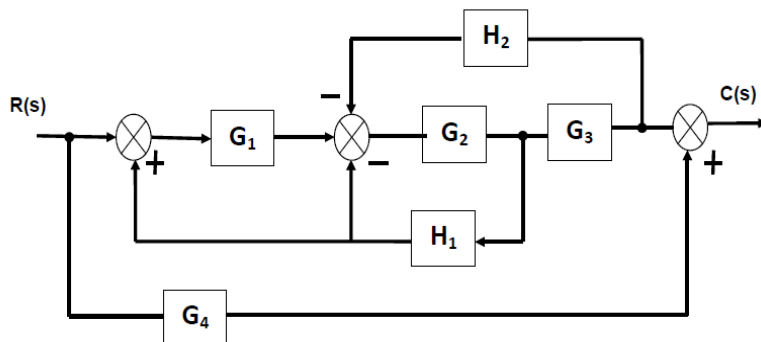

b) Sketch the root locus for $G(s)H(s) = K / S(S+4)(S^2+4S+10)$ (10)

- Q.3 a) Draw Bode plot and find gain margin and phase margin for

$$G(s)H(s) = \frac{64(S + 2)}{S(S + 0.5)(S^2 + 3.2S + 64)} \quad (10)$$

- b) For a system shown in fig. with unity feedback, find time domain specifications when a step input is applied

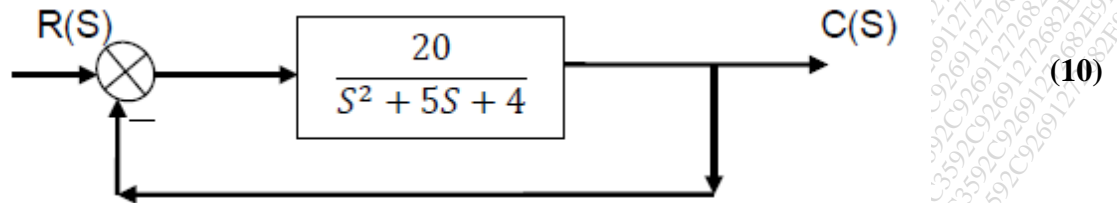

- Q4 a) Find Transfer function of

$$\begin{bmatrix} \dot{x}_1 \\ \dot{x}_2 \end{bmatrix} = \begin{bmatrix} -5 & -1 \\ 3 & -1 \end{bmatrix} \begin{bmatrix} x_1 \\ x_2 \end{bmatrix} + \begin{bmatrix} 2 \\ 5 \end{bmatrix} r(t) ; y = [1, 2] \begin{bmatrix} x_1 \\ x_2 \end{bmatrix} \quad (10)$$

- b) Obtain the state model for the system with transfer function

$$\frac{Y(s)}{U(s)} = \frac{3s + 4}{s^2 + 5s + 6} \quad (10)$$

- Q5 a) The open loop transfer function of a unity feedback system is given by $G(s) = 1/[S(S+1)(2S+1)]$. Sketch the polar plot and determine the gain margin and phase margin. (10)

Draw the Nyquist plot of the given system and comment on the stability.

b) $G(s) = \frac{1}{s(s+4)(s+8)} ; H(s) = 1 \quad (10)$

- Q6 Attempt any two from the following (20)

- a) Write a short note on Robust control system (10)
- b) Explain the correlations between time and frequency domain specifications of the system (10)
- c) Derive an expression for output response of a second order under damped control system. Assume the input to be unit step signal. (10)