

Time: 3 Hours

Marks: 80

1. Attempt Any Four Questions
2. Question No. 1 is Compulsory
3. Marks to the right indicate full marks
4. Assume suitable data wherever necessary.

Q1. Solve Any Four

10

- a) Draw block diagram and obtain transfer function of a simple closed loop system, with a forward path gain as $G(s)$ and feedback path gain as $H(s)$
- b) In complex “s” plane show pole locations for under damped, critically damped and over damped control systems.
- c) What are the effects of feedback on a system?
- d) Explain Importance of mathematical modeling.
- e) What is state transition matrix? State the properties of state transition matrix.

- 2a) Determine the transfer function C/R of a control system shown by following block diagram **10**

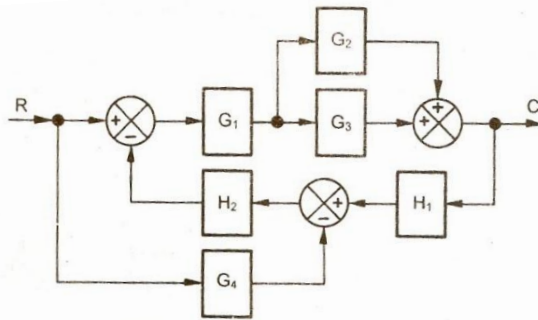

- 2b) Draw a Signal flow graph of the system in 2 a) and Obtain overall transfer function using Mason's Gain Formula **10**

- 3a) Define Controllability and Observability. Check the Controllability and Observability of the following State Space Model. **10**

$$\dot{x} = \begin{bmatrix} 2 & 1 \\ 1 & -2 \end{bmatrix} x + \begin{bmatrix} 1 \\ 1 \end{bmatrix} u;$$

$$y = [0 \quad 1]x$$

- 3b) For the given state variable model, obtain transfer function. **10**

$$\dot{x} = \begin{bmatrix} 0 & 1 \\ -2 & -3 \end{bmatrix} x + \begin{bmatrix} 1 \\ 0 \end{bmatrix} u:$$

$$y = [1 \quad 0]x$$

- 4a) Sketch Bode plot for a system whose open loop transfer function is **10**

$$G(s) = \frac{0.354 (s + 1)(1 + 0.05 s)}{s(1 + 0.025 s)}$$

- 4b) Sketch root locus for a unity feedback system, whose open loop transfer function is given as **10**

$$G(s) = \frac{K}{s(s + 2)(s + 4)}$$

- 5a) The open loop transfer function of a unity feedback system is given as **10**

$$G(s) = \frac{K}{s(s^2 + 4s + 13)}$$

Find the range of K for stability using Routh's stability criterion.

- 5b) Write the expression for a unit step response for a general second order system. Hence derive the expression for time to peak overshoot. **10**

- 6a) A unity feedback system has open loop transfer function as **10**

$$G(s) = \frac{40(s + 2)}{s(s + 1)(s + 4)},$$

Determine i) Type of a system, ii) Static error coefficients and iii) steady state error for ramp input with magnitude of 4.

- 6b) Write short note on any one of the following: **10**

- (i) Advances in Control Systems.
(ii) PID Controller
