

- N.B.** (1) Question number 1 is compulsory.
 (2) Attempt any 3 questions from remaining.
 (3) Assume suitable data if required.
 (4) Figure to the right indicates full marks.

Q1. Attempt any four questions in Q1.

[20]

- a) Explain lead and lag compensator.
- b) What are the properties of state transition matrix?
- c) Explain Controllability and Observability with necessary condition for stability.
- d) Explain Mason Gains' Formula with its need.
- e) Explain the effect of addition of pole and zero to a system.

Q2. A) Find the transfer function $C(s)/R(s)$ of the following system using block diagram technique.

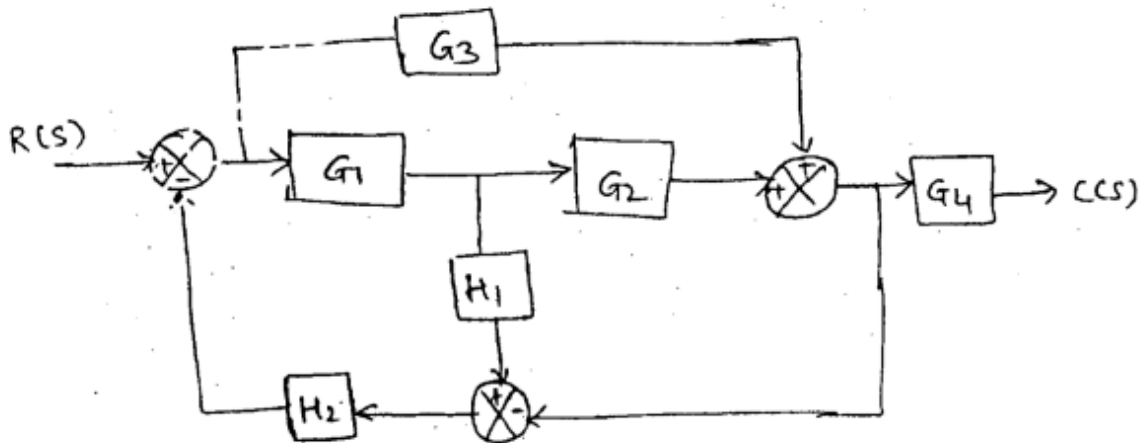

[10]

Q2. B) Consider Unity feedback control system with open loop transfer function given as

[10]

$$G(s)H(s) = \frac{k(s+1)(s+2)}{(s+3)(s-3)}$$

Plot the Root Locus and find the gain at which system is critically damped.

Q3. A) Write a note on advances in control system.

[10]

Q3. B) Obtain the state variable model of the transfer function –

[10]

$$\frac{Y(s)}{R(s)} = \frac{3s + 4}{s^2 + 4s + 3}$$

TURN OVER

Q4. A) Check controllability and observability for the system described by [10]

$$\dot{x} = \begin{bmatrix} 0 & 6 & -5 \\ 1 & 0 & 2 \\ 3 & 2 & 4 \end{bmatrix} x + \begin{bmatrix} 0 \\ 1 \\ 2 \end{bmatrix} u$$

$$Y = [1 \quad 2 \quad 3] x$$

Q4. B) Determine the stability of the system having characteristic equation [10]

$$s^8 + 5s^6 + 2s^4 + 3s^2 + 1 = 0$$

Q5. A) Construct the Bode Plot for the following transfer function. Comment on stability. [10]

$$G(s)H(s) = \frac{10}{s(s+1)(s+5)}$$

Q5. B) List the performance specifications of Time Response Analysis and derive any four of them. [10]

Q6. A) Explain Adaptive Control System. [20]

Q6. B) Explain PID Controller.

Q6. C) Find the range of K for the system to be stable

$$S^4 + 7s^3 + 10s^2 + 2ks + k = 0.$$

Q6. D) Draw polar plot for the transfer function given by

$$G(s) = \frac{12}{s(1+s)}$$