

[Time: 3 Hours]

[ Marks: 80]

Please check whether you have got the right question paper.

- N.B:
1. Question No 1. is **compulsory**.
  2. Attempt **any three** from the rest.
  3. Write neat and clean
  4. Writing answer directly for numerical will not be considered for marks allotment
  5. Assume any suitable data wherever required.

**Q.1** Answer **any four** (20)

- a) Explain input and output characteristic of FET.
- b) Explain the ripple factor in case of center tapped full wave rectifier with C filter.
- c) Explain the Nyquist criteria of oscillation.
- d) Explain voltage shunt current feedback amplifier.
- e) Explain enhancement type MOSFET.

**Q.2** (a) Explain collpit oscillator with the help of suitable circuit diagram. Derive the expressing of frequency for oscillation and necessary condition for oscillation. (10)

(b) Explain double biased clipper with the help of suitable circuit and waveform. (10)

**Q.3** (a) For the given circuit find steady state DC parameters  $I_{cq}$  and  $V_{ceq}$ . Given  $\beta = 100$  and  $V_{be} = 0.7v$ . Also state in which region the circuit in working. (10)

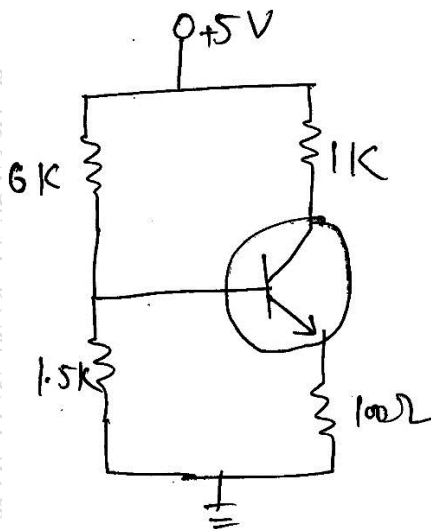

(b) Derive the expressing for stabilization factors for voltage divider biased circuit of BJT. (10)

- Q.4** (a) Draw the circuit diagram of cascade and cascade amplifiers and differentiate it. (10)  
 (b) Given  $V_{GG} = 1.5V$ ,  $V_{DD} = 15V$ ,  $R_D = 1.5k\Omega$ ,  $R_G = 1.5k\Omega$ ,  $I_{DSS} = 15mA$ ,  $V_P = -4V$  (05)  
 Determine  $V_{GS}$  and  $I_D$  and  $V_{DS}$ .

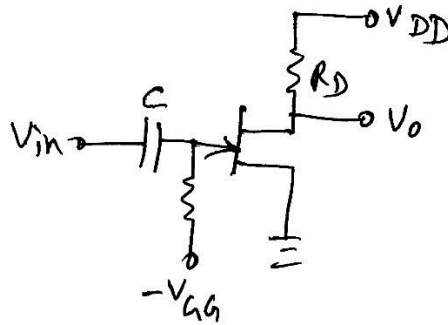

- (c) In JEET circuit show with self bias  $V_{DD} = 25V$ ,  $R_D = 3k\Omega$ ,  $R_S = 400\Omega$ ,  $I_D = 2mA$  (05)  
 Determine  $V_{DS}$  and  $V_{GS}$

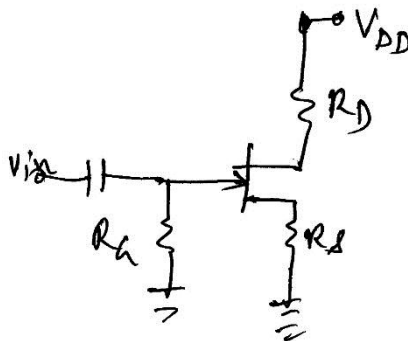

- Q.5** (a) Draw and explain the h-parameter model of BJT and derive the expression for  $A_v$ ,  $A_i$ ,  $R_i$ . (10)  
 Consider CE configuration.

- (b) Explain various configuration of feedback amplifier. Explain current series feedback in detail. (10)

- Q.6** Write short note on any two (20)

- (a) Thermal runaway in BJT and FET  
 (b)  $r_e$  model of BJT  
 (c) RC phase shift oscillator.