

**(3 Hours)**

**[Total Marks:80]**

- N.B.** (1) Question No.1 is compulsory.  
 (2) Attempt any Three from the rest.  
 (3) Figure to right indicate full Marks.  
 (4) Assume the suitable data if it is necessary.
- Q.1** Answer any Four of the following.
- (a) Justify Zener diode can be used as a voltage regulator. 5M
  - (b) Explain Barkhausen criterion for sustained oscillations. 5M
  - (c) Explain different types of coupling. 5M
  - (d) Explain thermal runaway and stabilization in BJT. 5M
  - (e) Explain the effect of negative feedback on bandwidth and overall gain. 5M
- Q.2** (a) Draw circuit diagram of full wave bridge rectifier with CLC filter. Explain its working with neat sketches and Derive expression for ripple factor. 10M  
 (b) What are the types of MOSFET? Explain their construction and working. 10M
- Q.3** (a) In a circuit shown in Fig.1 determine  $I_{CQ}$  and  $V_{CEQ}$ . Draw the DC load line on output characteristics and show the location of Q-point. Comment on the region of operation. 10M

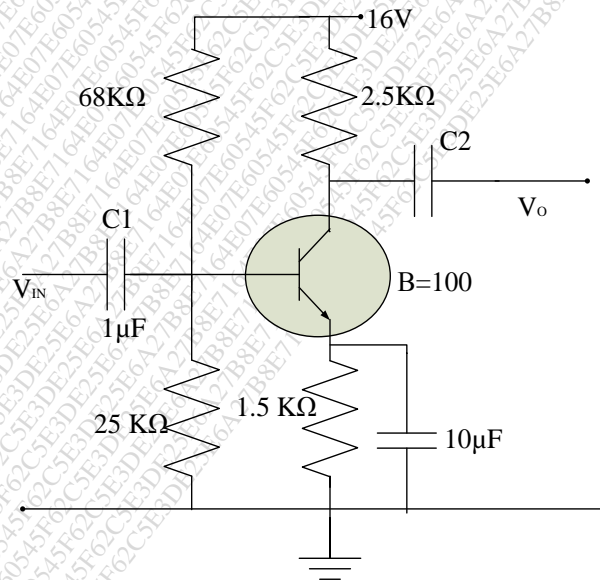
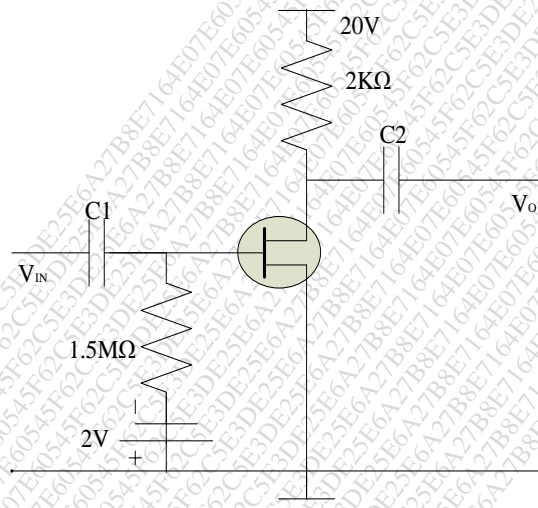

**Fig.1**

- (b) Draw circuit diagram of RC phase shift oscillator. Derive an expression for its frequency of oscillation. 10M

**Q. P. Code: 23920**

- Q.4** (a) Derive expression for voltage gain, output impedance and input impedance of common source JFET amplifier. 10M  
 (b) Explain the working of CE amplifier with its frequency response. 10M
- Q.5** (a) For the Common Source amplifier using fixed bias configuration as shown in Fig.2, the Q point is defined as  $I_{DQ} = 6 \text{ mA}$  and  $V_{GSQ} = -2 \text{ V}$ . The values of  $I_{DSS}$  and  $V_P$  are  $10 \text{ mA}$  and  $-7 \text{ V}$  respectively. The value of  $Y_{OS} = 40 \mu\text{S}$ . Calculate (a)  $g_m$  (b)  $r_d$  (c)  $Z_i$  (d)  $Z_o$  (e)  $A_v$  10M



**Fig.2**

- (b) Compare different biasing methods of JFET. 5M  
 (c) Compare the different negative feedback amplifiers. 5M
- Q.6** Answer any Two of the following.
- (a) Write short note on H-parameter model. Derive the necessary expression for  $A_v$ ,  $Z_i$ ,  $Z_o$ . 10M  
 (b) What is Darlington configuration? Derive the expression of voltage gain for Darlington pair emitter follower. 10M  
 (c) Draw neat diagram of UJT relaxation oscillation. Explain its operation. Derive the expression for frequency of output signal. Draw various waveforms. 10M

\*\*\*\*\*