

Time: 3 Hours

Marks: 80

Note:

- 1) Question No. 1 is compulsory.
- 2) Attempt any **three** questions from remaining **five** questions.
- 3) Make suitable **assumption** wherever **necessary** and mention the same.
- 4) Use graph paper and semilog paper wherever necessary.
- 5) **Figures** to the **right** indicate **full marks**.

Q.1) Attempt **any four**:

- A) Explain the difference between open loop and closed loop system. **05 Marks**
- B) State an advantages of using state space analysis over classical control approaches. **05 Marks**
- C) Write a short note on transient response specifications. **05 Marks**
- D) Explain the effect of addition of open loop poles and zeros on root locus. **05 Marks**
- E) Explain stability in polar plot. **05 Marks**

Q.2) A) Find overall transfer function $C(s)/R(s)$ of the given system using block diagram reduction method. **10 Marks**

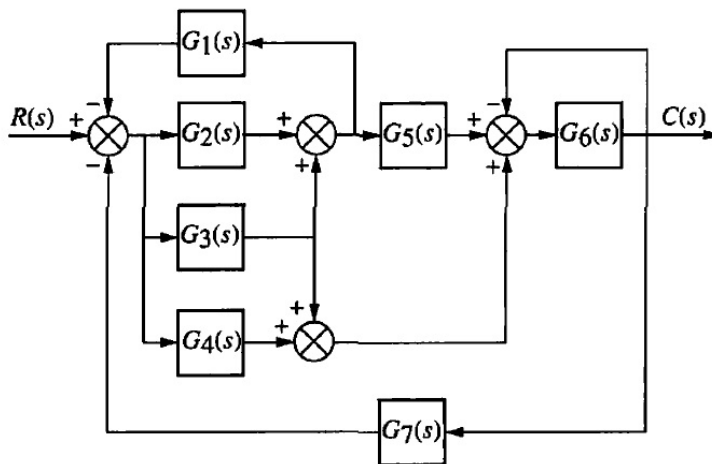

B) Find overall transfer function $C(s)/R(s)$ for the given signal-flow graph using mason's gain formula. **10 Marks**

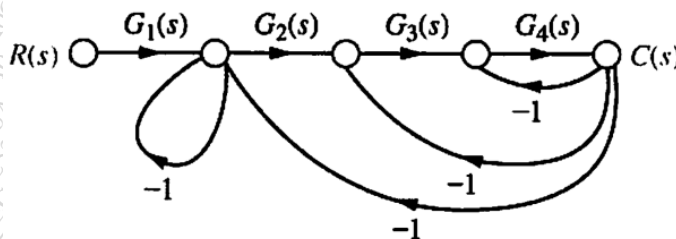

- Q.3) A) For a unity negative feedback system having $G(s) = 225 / (s*(s+12))$ determine all-time **10 Marks** domain specifications for unit step input.
- B) Sketch the complete root locus for the system given below. Also find the range of gain **10 Marks** K within which the system is stable. $G(s)H(s) = K / (s*(s+2)*(s+4)*(s+8))$.
- Q.4) A) For the system having $C(s)/R(s) = (s+5) / (s^3+9*s^2+24*s+26)$. Obtain the phase **10 Marks** variable form of state space model. Also draw the state model.
- B) Find the stable operating range of gain and the value of K_{marg} by using Routh – **10 Marks** Hurwitz criterion for the unity negative feedback system having $G(s) = K / (s*(s+9)*(s+15))$.
- Q.5) A) Draw the bode plot and determine gain margin and phase margin for the system **10 Marks** having $G(s)H(s) = 10000 / ((s+5)*(s+20)*(s+50))$
- B) Draw the nyquist plot and comment on stability for the system having **10 Marks** $G(s)H(s) = 20 / (s*(s+4)*(s-2))$
- Q.6) A) Determine the steady state error for system given below, where $R(s)$ is the ramp **07 Marks** input of magnitude 2. If it is desired to reduce existing error by 5% find new value of gain of the system.

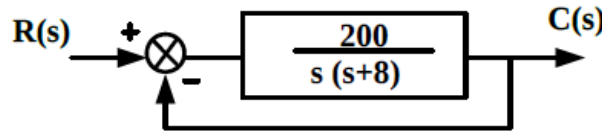

- B) Explain how to calculate static error constants from Bode magnitude plot. **07 Marks**
- C) Write a short note on AC servomotor. **06 Marks**
