

Time: 3 Hours

Total Marks: 80

N.B.

- 1) Question No. 1 is Compulsory
- 2) Out of remaining questions, attempt any three
- 3) Assume suitable data if required
- 4) Figures to the right indicate full marks

1 (A) Draw equivalent circuit for given magnetically coupled circuit.

05

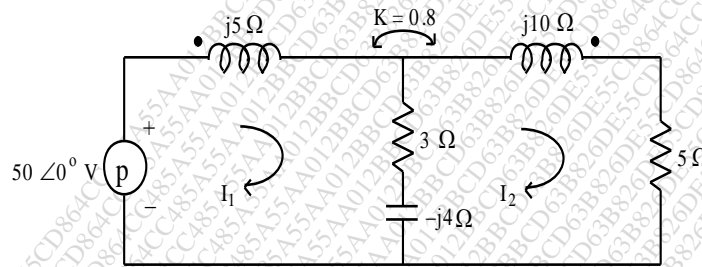

(B) In the network shown in Fig., at  $t = 0$ , switch is opened. Calculate  $v, \frac{dv}{dt}$  at  $t = 0+$ .

05

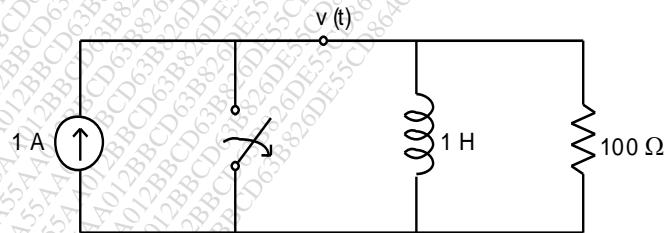

(C) The Z parameters of a 2 port network are,  $Z_{11} = 20 \Omega, Z_{22} = 30 \Omega, Z_{12} = Z_{21} = 10 \Omega$ . Find Y parameters.

05

(D) Two two port networks are connected in parallel. Prove that the sum of the corresponding individual parameters is equal to the overall y parameters.

05

- 2 (A) The network of Fig. is under steady state with switch at position 1. At  $t = 0$ , switch is moved to position 2. Find  $i(t)$ . 10

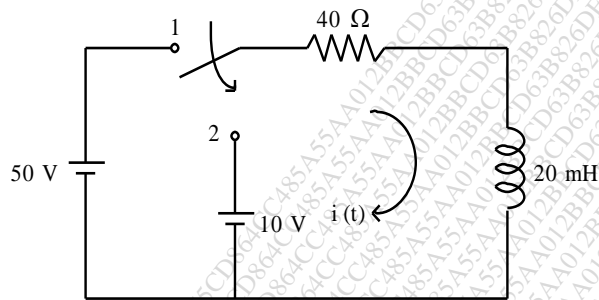

- (B) The Z-parameters of a two port are :  $Z_{11} = 20 \Omega$ ,  $Z_{12} = Z_{21} = 10 \Omega$ ,  $Z_{22} = 30 \Omega$ . Find equivalent T-network. 10

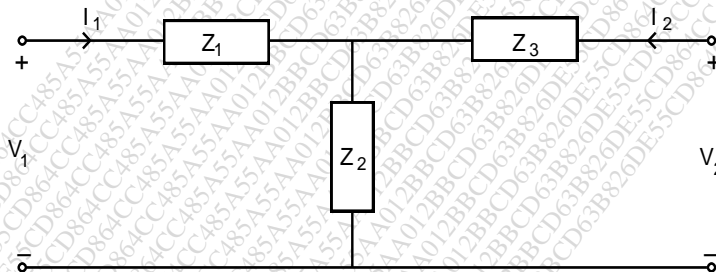

- 3 (A) Determine Thevenin's equivalent network for the Fig. shown. 10

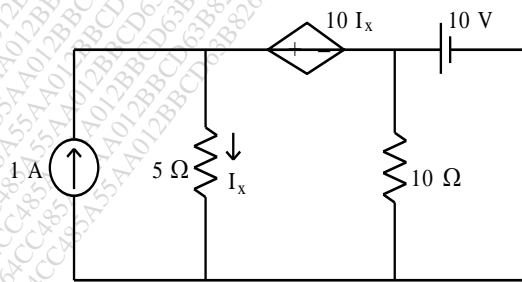

- (B) The parameters of a transmission lines are  $R = 65\Omega/\text{km}$ ,  $L=1.6\text{mH}/\text{km}$ ,  $G = 2.25 \text{ mmho}/\text{km}$ ,  $C=0.1\mu\text{F}/\text{km}$ . Find 10
- i) Characteristic Impedance

- ii) Propagation Constant
- iii) Attenuation Constant
- iv) Phase Constant at 1 kHz

4 (A) Determine whether following functions are positive real 10

i) 
$$\frac{s^4 + 2s^3 + 3s^2 + 1}{s^4 + s^3 + 3s^2 + 2s + 1}$$

ii) 
$$\frac{s^2 + 2s}{s^2 + 1}$$

(B) In the network of Fig. find  $V_0$ . 10

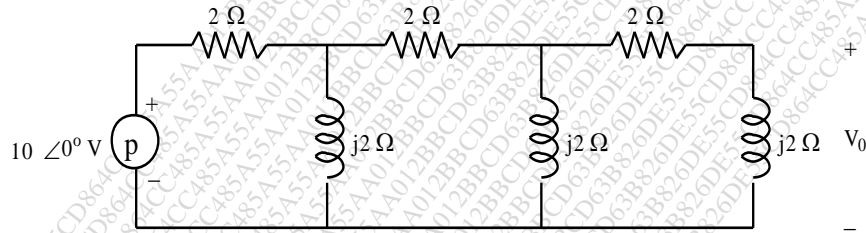

5 (A) Find Y-parameters for the network shown in Fig 10

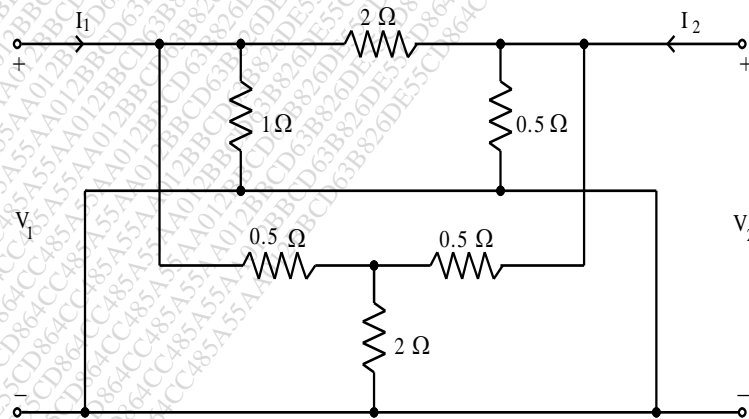

(B) Realize the following functions in Foster I and Foster II form 10

$$F(s) = \frac{4(s+1)(s+3)}{(s+2)(s+6)}$$

- 6 (A) A transmission line has a characteristics impedance of 50 ohm and terminate in a load  $Z_L = 25 + j50$  ohm. Use smith chart and Find VSWR and Reflection coefficient at the load. **10**
- (B) The switch in Fig. is open for a long time and closes at  $t = 0$ . Determine  $i(t)$  for  $t > 0$ . **10**

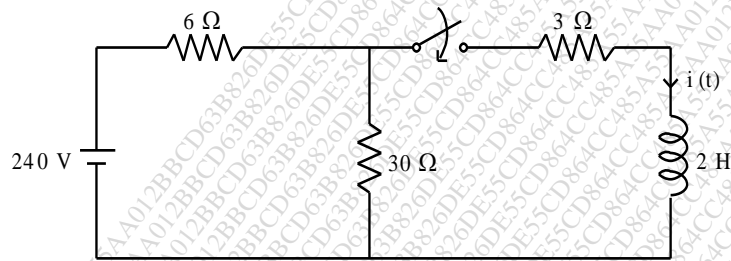

\*\*\*\*\*